

ASIA

TILLING ROTARY & ROTARY TILLER

OPERATING MANUAL & PARTS LIST

TR-60 / RT-60

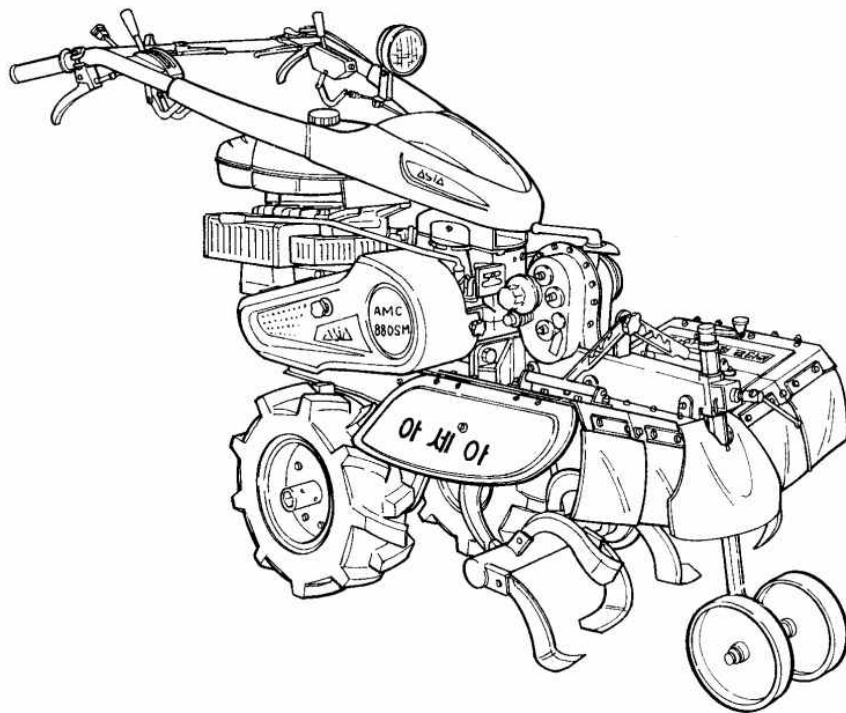

ASIA 아세아텍
ASIA TECHNOLOGY CO.,LTD.

Contents

1. Rotary tiller	3
2. Tilling Rorary	4

1. Rotary tiller(option)

1) Specification

Type		RT-60
Working width (mm)		625
Working depth (mm)		50 ~ 150
Blade	General	Left, right each 8 units
Rotation diameter (mm)		390
Working range	Traveling	Forward 1,2 range (low speed condition of main clutch)
	Rotary	finely : 1range
Working efficiency (ha/day)		0.5 ~ 1

2) Working use

- ① Cultivating and Levelling
- ② Weed cutting of mid-tilling
- ③ Surface application

3) The method of attachment of rotary tiller on the cultivator

- ① Attach the rotary tiller with dividing of left and right in the location of engine like [Fig.1].

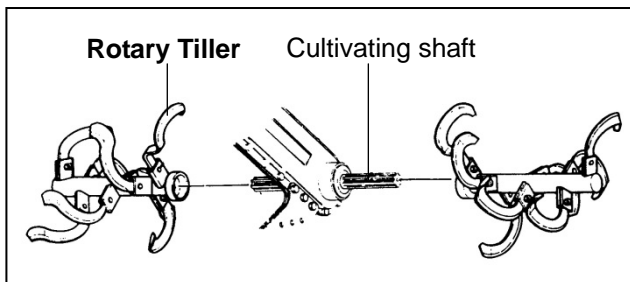

Fig.9-1

4) The working point of rotary tiller

- ① Working at rotary, please prevent the approaching of the person in front of machine.
- ② After work at rotary, the leveling works in [Reverse 1st]

2. Tilling rotor(option)

1) Specification

Type		TR-60
Working width (mm)		625
Working depth (mm)		50 ~ 150
Blade	General	Left, right each 8 units
Rotation diameter (mm)		390
Working range	Traveling	Forward 1,2 range Reverse 1,2 range (low speed condition of main clutch)
	Rotary	thickly : 1range, finely : 1range
Working efficiency (ha/day)		0.5 ~ 1

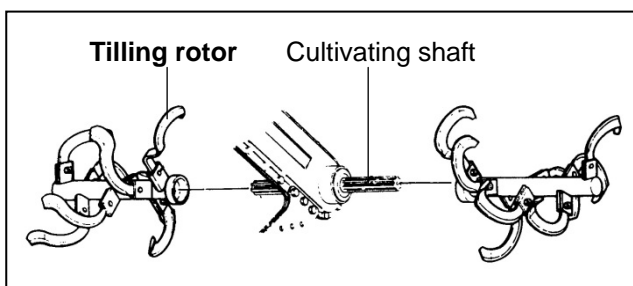

Fig.9-2

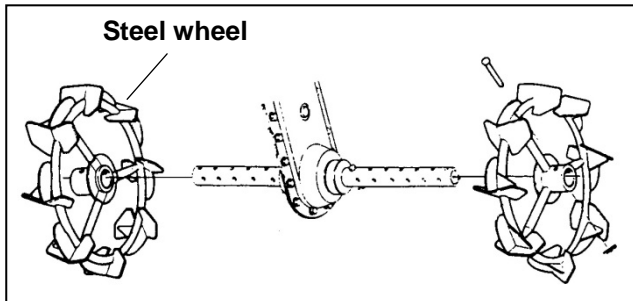

Fig.9-3

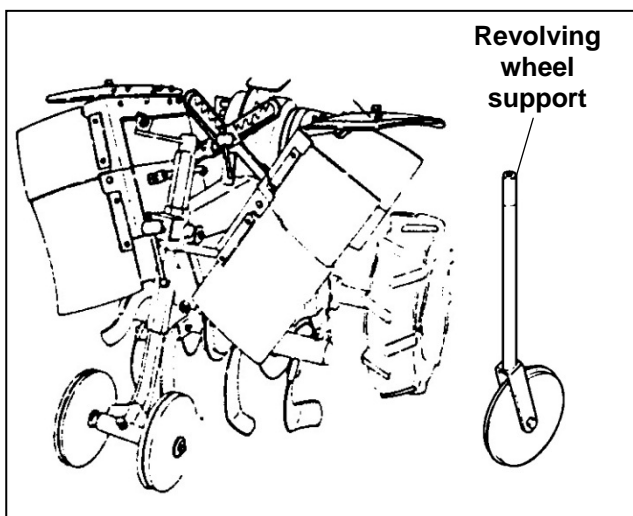

Fig.9-4

2) Working use

- ① Cultivating and Levelling
- ② Weed cutting of mid-tilling
- ③ Surface application
- ④ Rotary and leveling in the wet paddy

3) The method of attachment of tilling rotary on the cultivator

① Field tilling rotor

Attach the tilling rotor with dividing of left and right in the location of rotary like [Fig.2].

② Wet paddy tilling rotor(option)

Remove the wheel(rubber), and exchange the steel wheel like [Fig.3].

Disassemble the tail wheel adjust handle and assemble revolving tail wheel ass'y as shown in [Fig.4].

4) The working point of tilling rotor

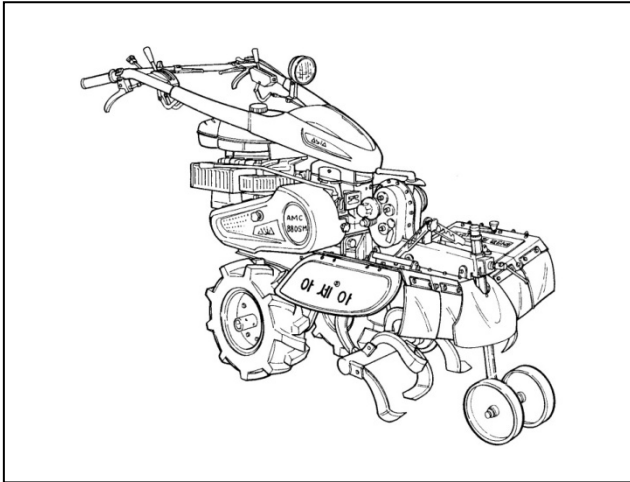

Fig.9-5

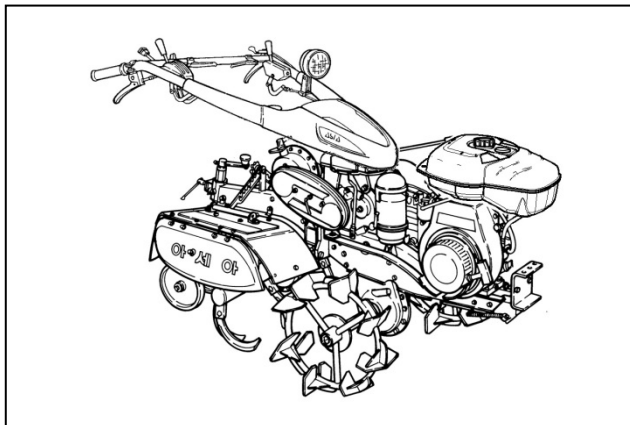

Fig.9-6

- ① Field tilling rotor work
 - Leveling and cultivation conform with rotary operation method
 - Working at rotary, please prevent the approaching of the person in front of machine.
 - After work at rotary, the leveling works in [Reverse 1st]

- ② Wet paddy tilling rotor
 - Turn on the opposite side of the gandle, as shown in [Fig. 6], please fix the rotary side.
 - Please assemble in [thickly] direction the link chain case.
 - Lower the cover of the rotary, muddy water does not scatter to the operator.
 - Please work setting is forward 1 range, rotary 1 range.
 - Turn the tail wheel adjust handle to adjust to the depth of the rotary.

Important

- As the rotary working, lift the handle when the wheel of machine is slipped and press the handle when the machine goes to forward lightly, following to the soil condition and working depth.



Caution

■ Protect the approach of the person around the machine when the rotary working.

6) Working use

Operation Type	Operating method	Implement	Handling method
Field tilling rotor work	1) If you do after another work ① Change the implement ② Assemble in [finely] direction the link chain case. 2) Adjust 10 ~ 20cm depth work, the upper cover is firmly fixed in the clamp bolt to be horizontal. 3) After fertilization work in spring fertilizing season, summer fertilizing season, fall fertilizing season, cultivating and leveling at the same time you can get the dual effect. 4) The leveling has to reverse work because there is no trace of the wheels on the surface.	1) Tilling rotor left , right 2) Rubber wheel set 3) Assemble the rubber wheel, it must be narrower than tilling rotor width	- Traveling speed is forward low speed 1 range - Rotary speed is finely 1 range - It is possible depending of the soil, and also do the forward 2 range
Wet paddy tilling rotor work	1) Purchase wet paddy implement and assemble. 2) Turn to reverse the handle, work to tilling rotor in the same way. 3) Rotary work in wet paddy, refer to [Fig.6].	1) Tilling rotor left, right 2) Steel wheel set 3) Revolving tail wheel set	- The following is the same as the above. (Turn to reverse the handle)

THE ASIA PARTS LIST

***Never use other than GENUINE ASIA PARTS
they are standardized, tested and proved.***

***Using genuine parts saves your time and money above all.
Ensures that your machine will always be ready for immediate work.***

CONTENTS

No.	Group	Description	Page
01	AB010	Tilling Rotor (TR-60)	8
02	AB070	Rotary Tiller (RT-60)	10

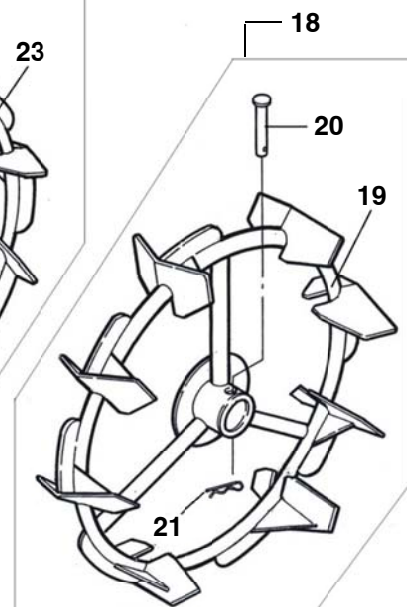
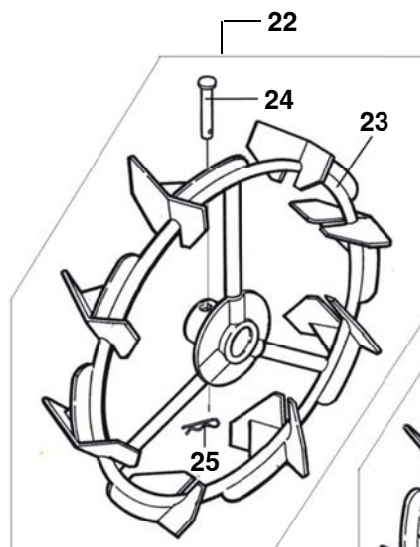
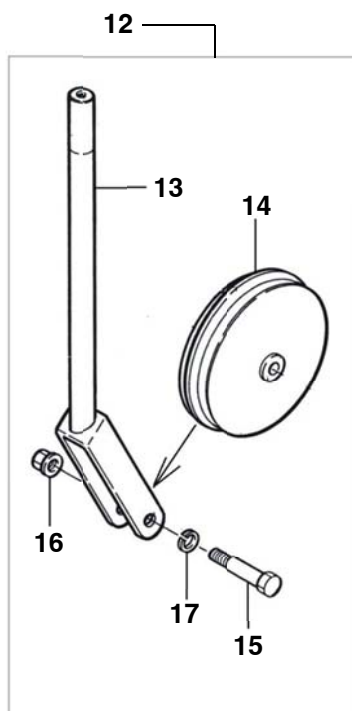
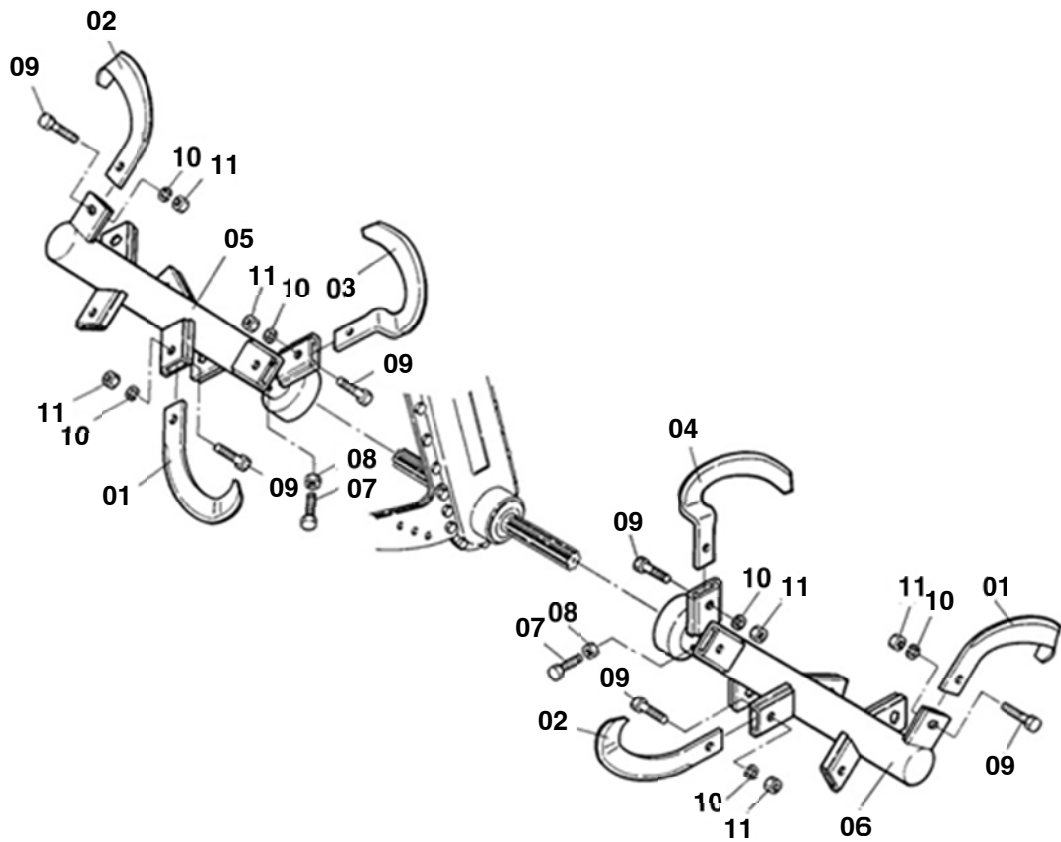

ASIA PARTS LIST

2017.10.

AB010**Tilling Rotor (TR-60)**

No.	Parts No.	Size	Parts Name	Q'ty	Remarks
01	TR-1001		Blade(L), Rotary	7	
02	TR-1002		Blade(R), Rotary	7	
03	TR-1003		Special Blade(L), Rotary	1	
04	TR-1004		Special Blade(R), Rotary	1	
05	AB010-10051-01		Tube(L), Rotary	1	
06	AB010-10061-01		Tube(R), Rotary	1	
07	DT-0708		Setting bolt	2	
08	A163-10Z	M10P1.5	Nut	2	
09	DT-0720		Bolt, Blade setting	16	
10	A204-10Z	M10	Spring Washer	16	
11	DT-0721		Nut	16	
12	TR-1015		Tail Wheel Ass'y	(1)	20~24
13	TR-1016		Support, tail wheel	1	
14	DT-0682B		Tail wheel	1	
15	TR-1018		Support bolt, Tail wheel	1	
16	A160-12Z	M12P1.25	Nut	1	
17	A204-12Z	M12	Spring Washer	1	
18	AB010-10191		Steel Wheel Ass'y(L)	(1)	26~28
19	TR-1009		Steel wheel(L)	1	
20	DT-0507A		Pin(B), Axle	1	
21	A321-14Z	JASO A 14	Snap Pin	1	
22	AB010-10201		Steel Wheel Ass'y(R)	(1)	30~32
23	TR-1010		Steel wheel(R)	1	
24	DT-0507A		Pin(B), Axle	1	
25	A321-14Z	JASO A 14	Snap Pin	1	

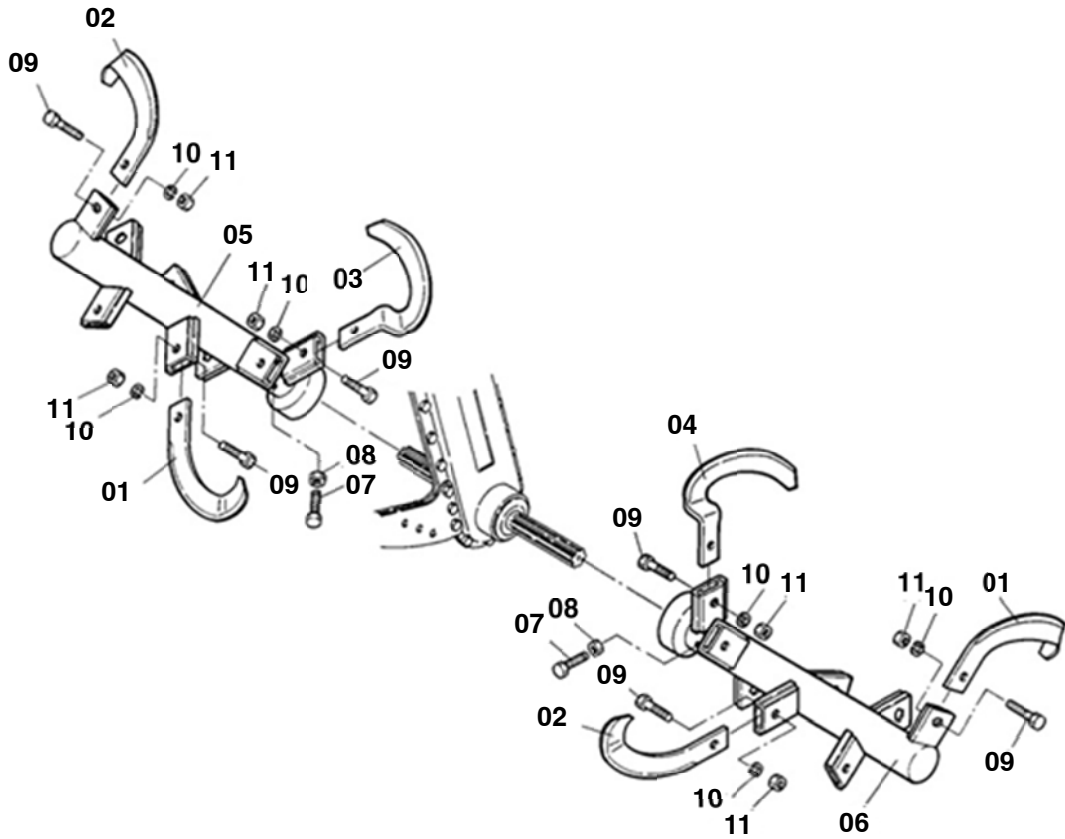

ASIA PARTS LIST

2017.10.

AB070**Rotary Tiller (RT-60)**

No.	Parts No.	Size	Parts Name	Q'ty	Remarks
01	TR-1001		Blade(L), Rotary	7	
02	TR-1002		Blade(R), Rotary	7	
03	TR-1003		Special Blade(L), Rotary	1	
04	TR-1004		Special Blade(R), Rotary	1	
05	AB010-10051-01		Tube(L), Rotary	1	
06	AB010-10061-01		Tube(R), Rotary	1	
07	DT-0708		Setting bolt	2	
08	A163-10Z	M10P1.5	Nut	2	
09	DT-0720		Bolt, Blade setting	16	
10	A204-10Z	M10	Spring Washer	16	
11	DT-0721		Nut	16	

ASIA TILLING ROTOR & ROTARY TILLER TR-60 / RT-60

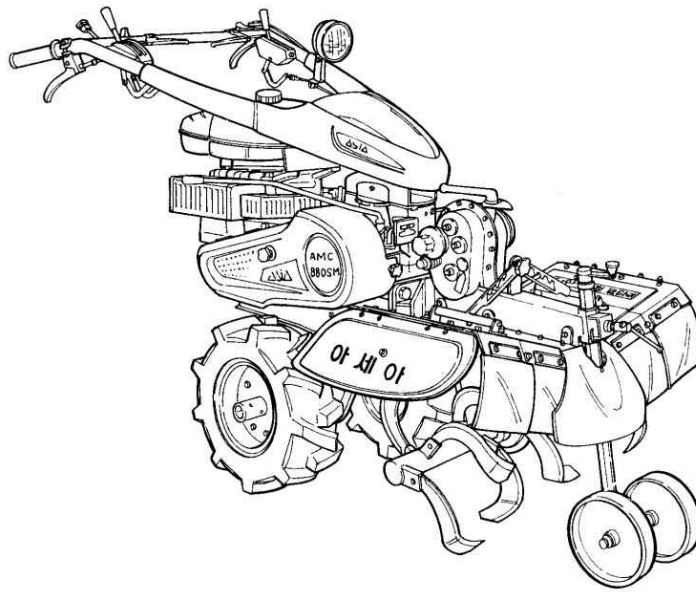

ASIA 아세아텍
ASIA TECHNOLOGY CO.,LTD.

Mailing Add. :

R.M.701, SHIN TAE YANG BLDG. 736-8, BANPO-DONG, SEOCHO-GU, SEOUL,
KOREA 137-810

<http://www.asiakor.com>

TEL : 02) 547-8098

FAX : 02) 547-0989